

st4.8x16 (x4)
B

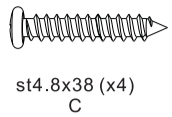

st4.8x38 (x4)
C

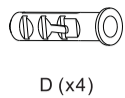

D (x4)

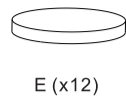

E (x12)

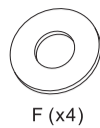

F (x4)

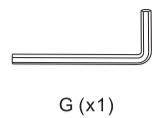

G (x1)

1

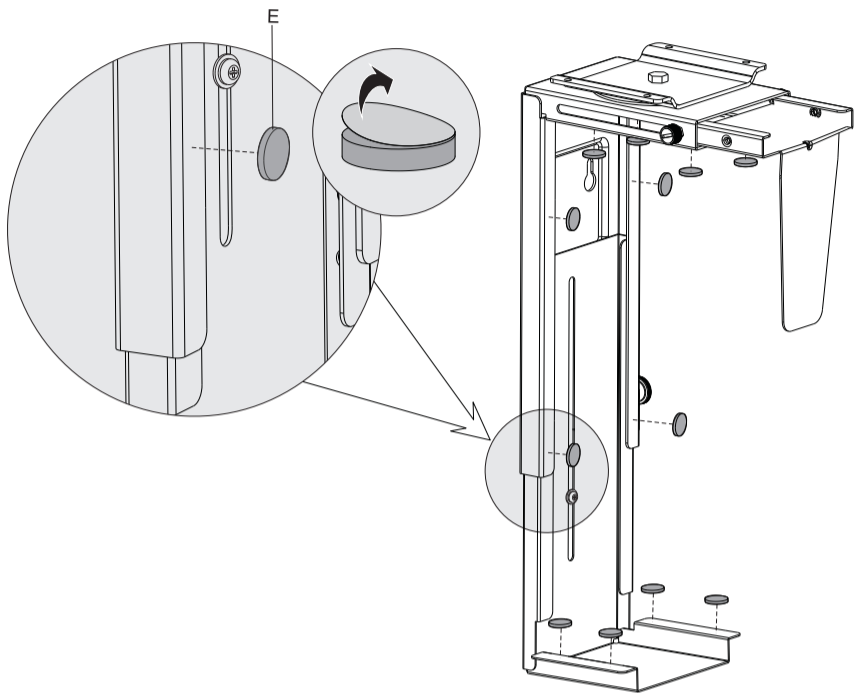

2

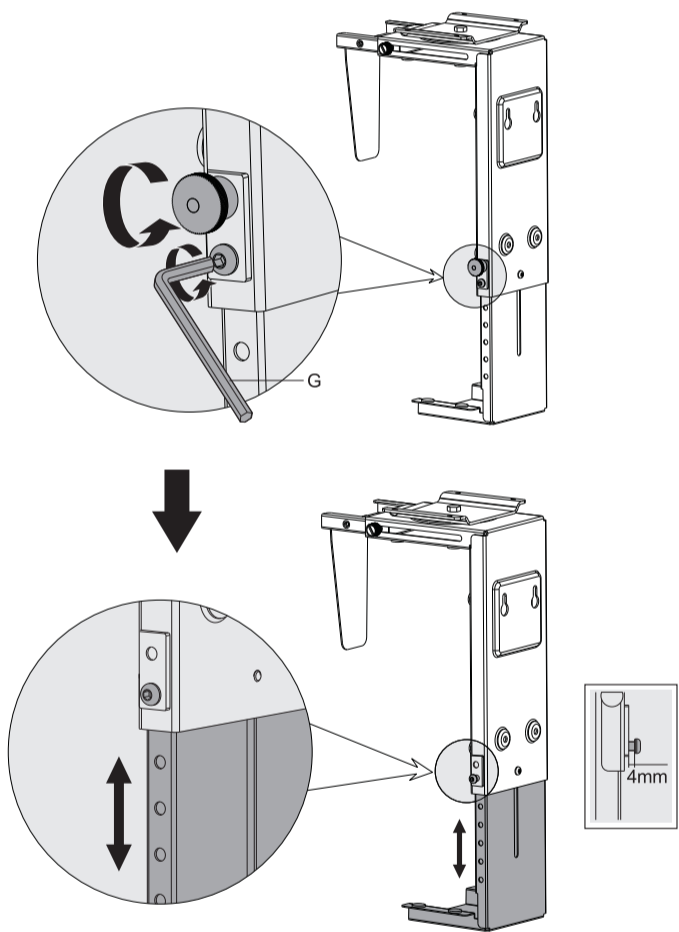

3

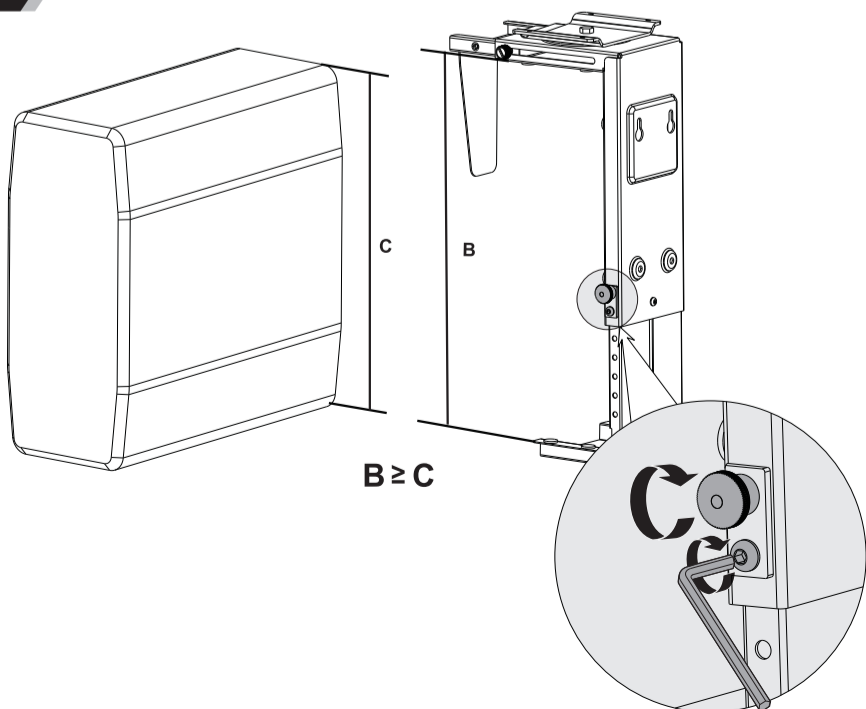

4a-1

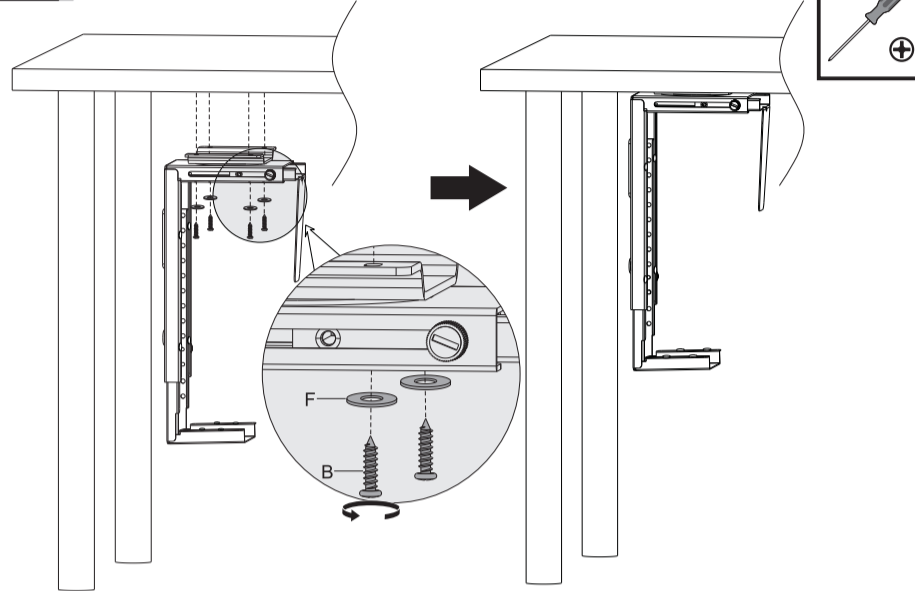

4a-2

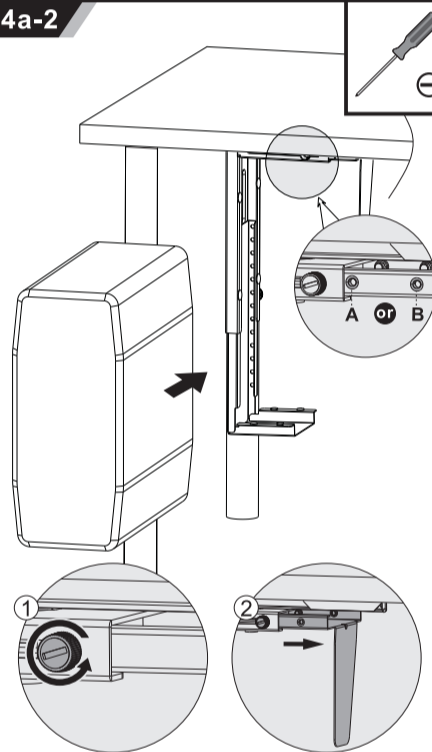

4a-3

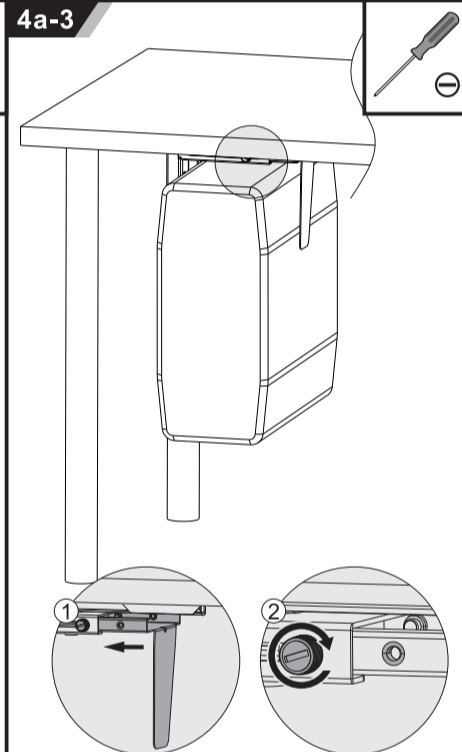

4b

