

A(x1)

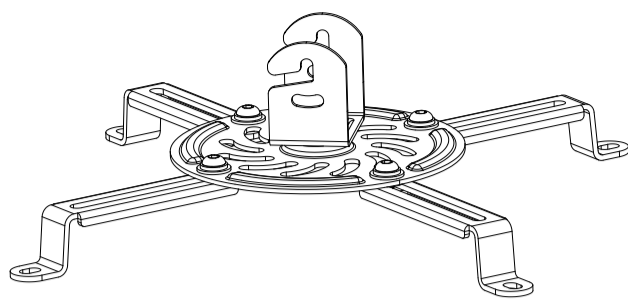

B(x1)

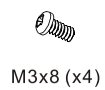

M3x8 (x4)
M-A



M4x10 (x4)
M-B



M5x10 (x4)
M-C



M6x10 (x4)
M-D



D3 (x4)
M-E



D4 (x4)
M-F



D5 Ø5xØ12 (x4)
M-G



D6 (x4)
M-H



M5x12 (x2)
M-I



D5 Ø5xØ10 (x2)
M-J



D5 (x2)
M-K



M-L (x1)



W-A (x4)



W-B (x4)



W-C (x4)

1a

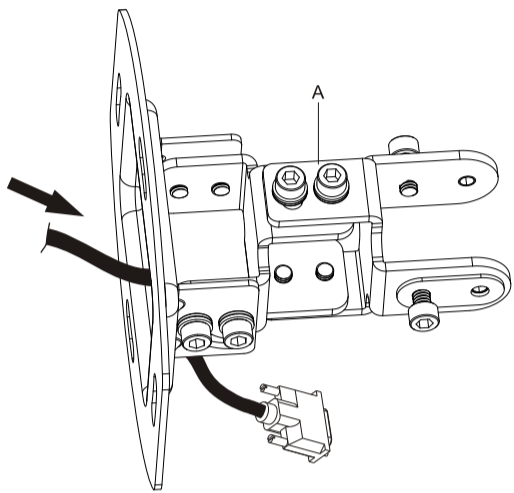

1b

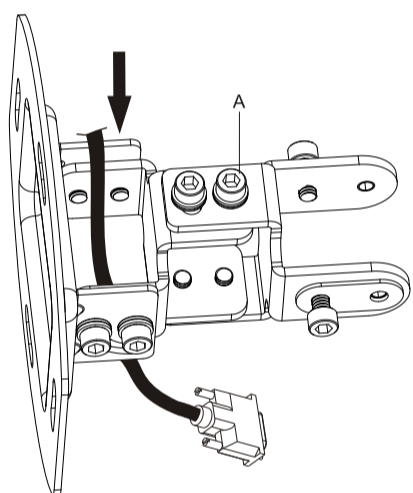

2a

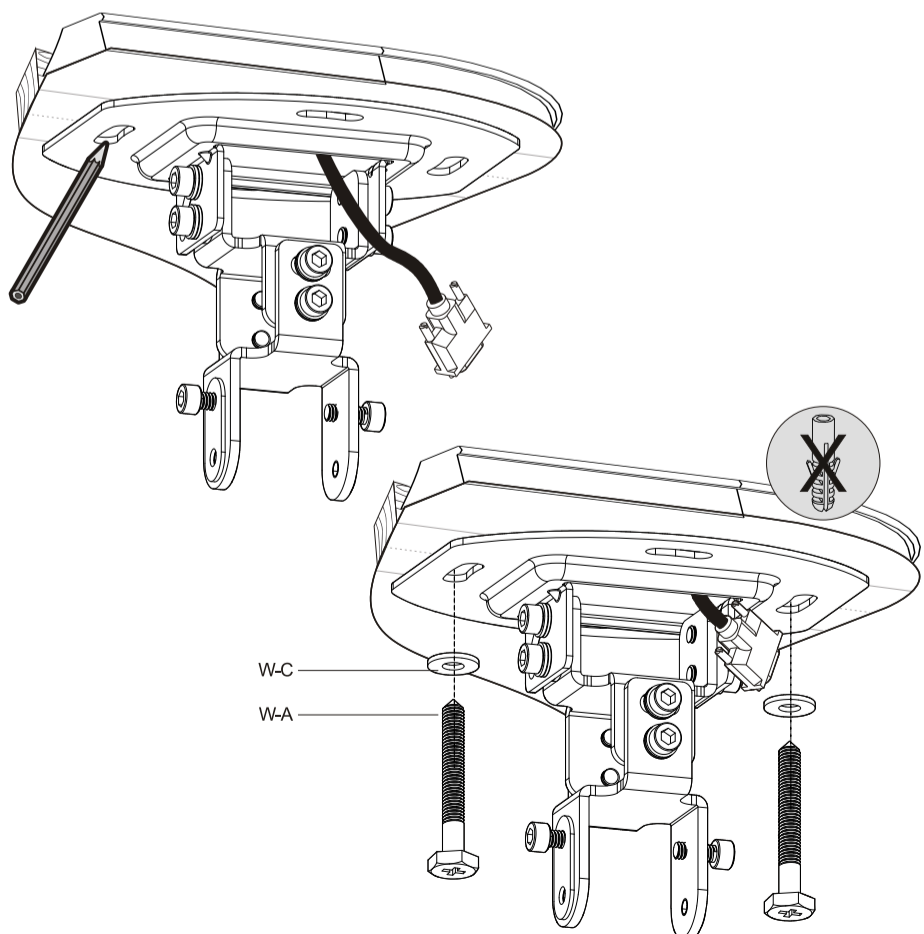

W-C
W-A

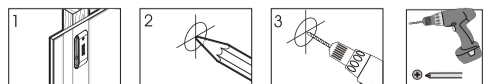

2b

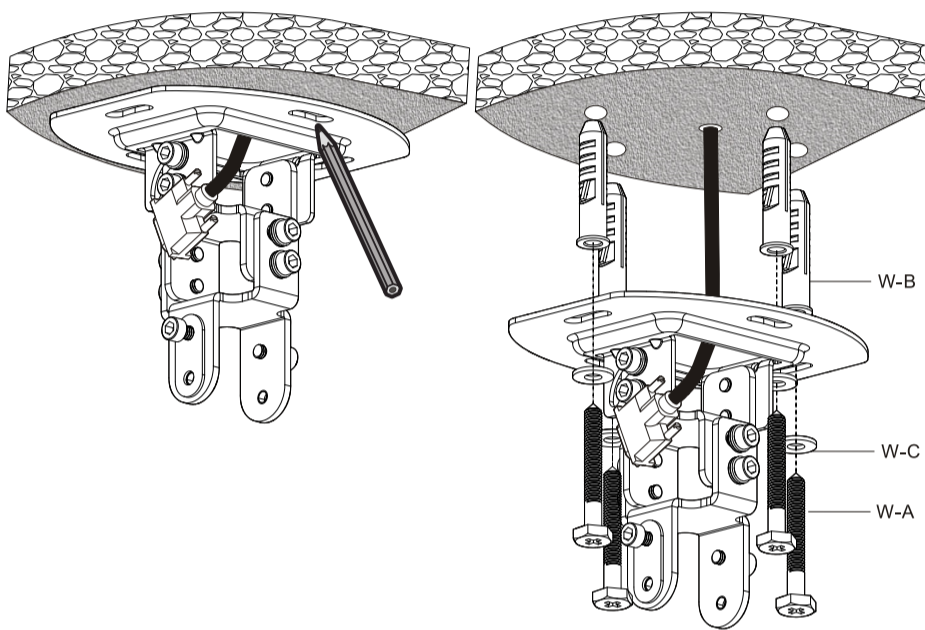

W-B

W-C

W-A

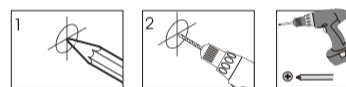

3

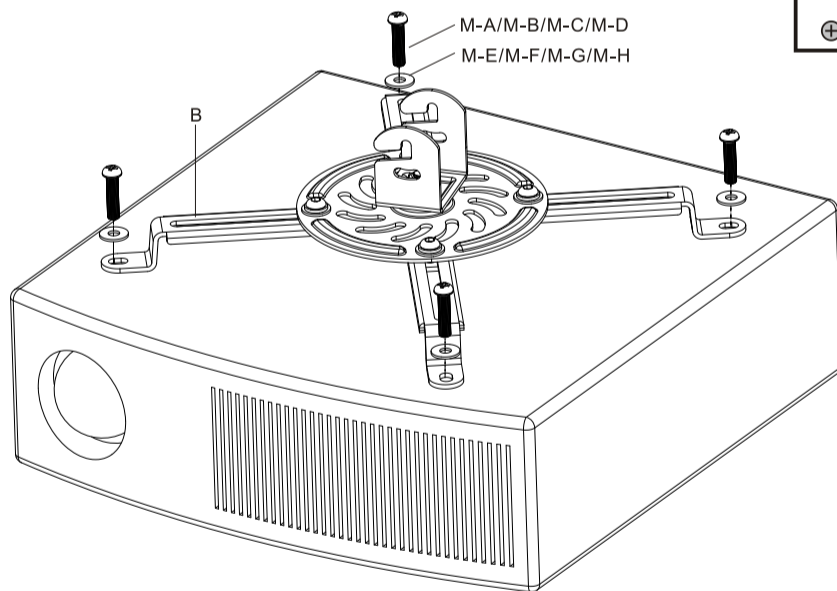

M-A/M-B/M-C/M-D
M-E/M-F/M-G/M-H

4

